

Silicoflex Deck Joint Seals

**Nebraska Department of Roads
AASHTO Midwest Bridge Preservation Conference
October 13, 2010, Detroit Michigan
Roe Enchayan, PE
Bridge Inspection Engineer**



SILICOFLEX

Bridge Deck Joint Sealing System

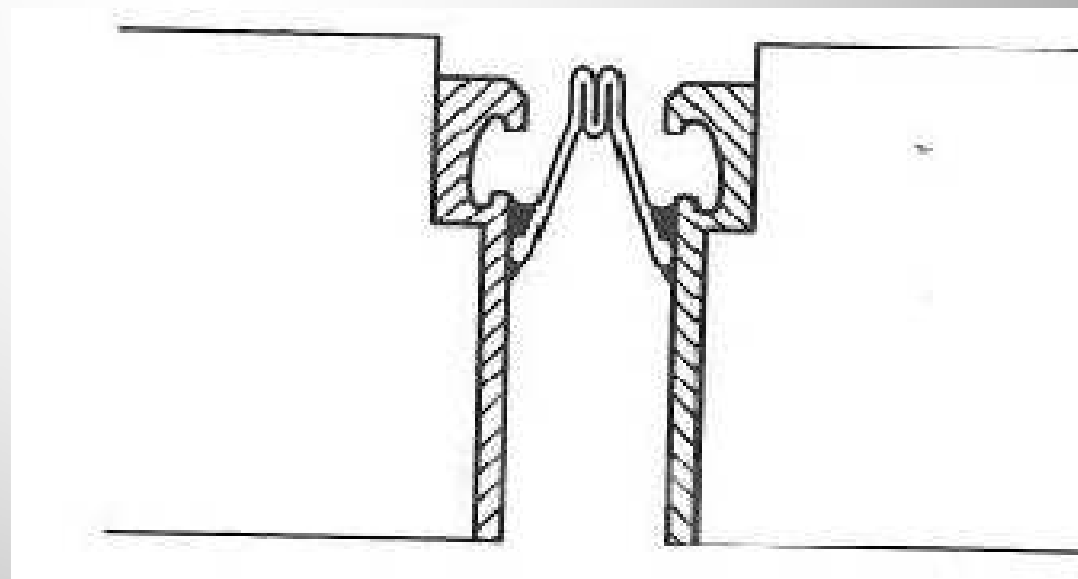



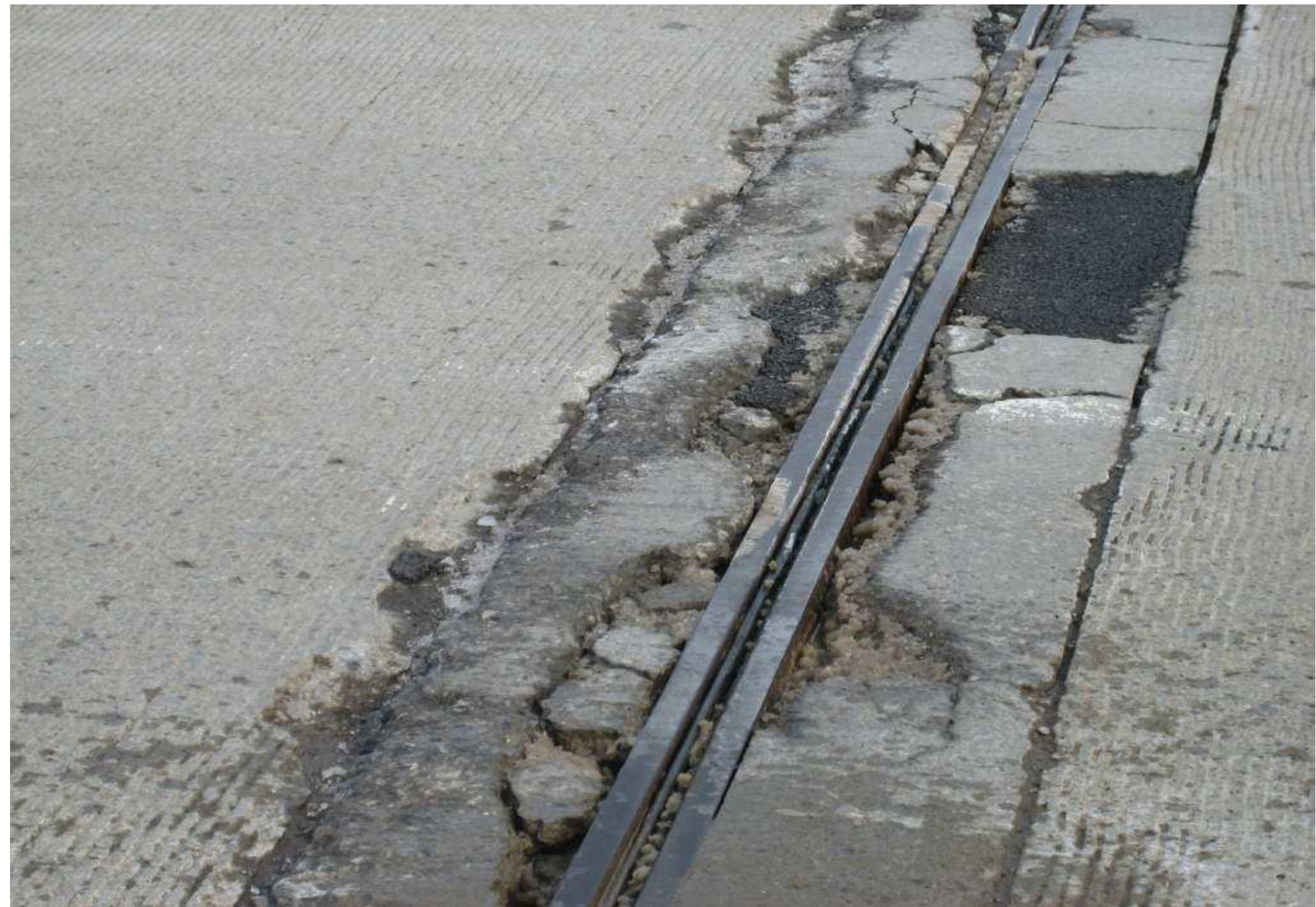

S067 01234



Silicoflex System

- **Two Component Primer**
- **Single-Component Silicone Locking Adhesive**
- **Preformed Silicone Extruded Gland**

Silicoflex System - Gland

Sizing Chart

Model	Inst. Width	Max Closure	Max Opening
	1.0 - 2.0 in. (25-50 mm)	0.5 in. (13 mm)	2.0 in. (50 mm)
	1.25 - 3.0 in. (31-75 mm)	0.75 in. (19 mm)	3.0 in. (75 mm)
	2.5 - 4.0 in. (63-100 mm)	1.0 in. (25 mm)	5.0 in. (125 mm)

Silicoflex System - Primer



Silicone Locking Adhesive





Silicoflex System - Gland

10/13/2010

AASHTO Midwest Bridge Preservation Conference – Detroit Michigan

Roe Enchayan, PE

Advantages of Silicoflex

- Bonds to Steel, Concrete or Elastomeric Concrete
- No Shop Drawings or Costly Fabrication
- Operating Temperature between
-60°F and 450°F
- Designed Never To Be In Tension
- Inorganic, Therefore U.V./Ozone Resistant
- Rapid Installation
- Long Lasting Solution To Sealing Joints
- **Maintenance Friendly**

Sand Blast



Apply Primer



Clean Gland



Apply Adhesive

10/13/2010

AASHTO Midwest Bridge Preservation Conference – Detroit Michigan

Roe Enchayan, PE



Install Gland



Support Gland



Reapply Adhesive



Finishing Tool



10/13/2010

AASHTO Midwest Bridge Preservation Conference – Detroit Michigan

Roe Enchayan, PE

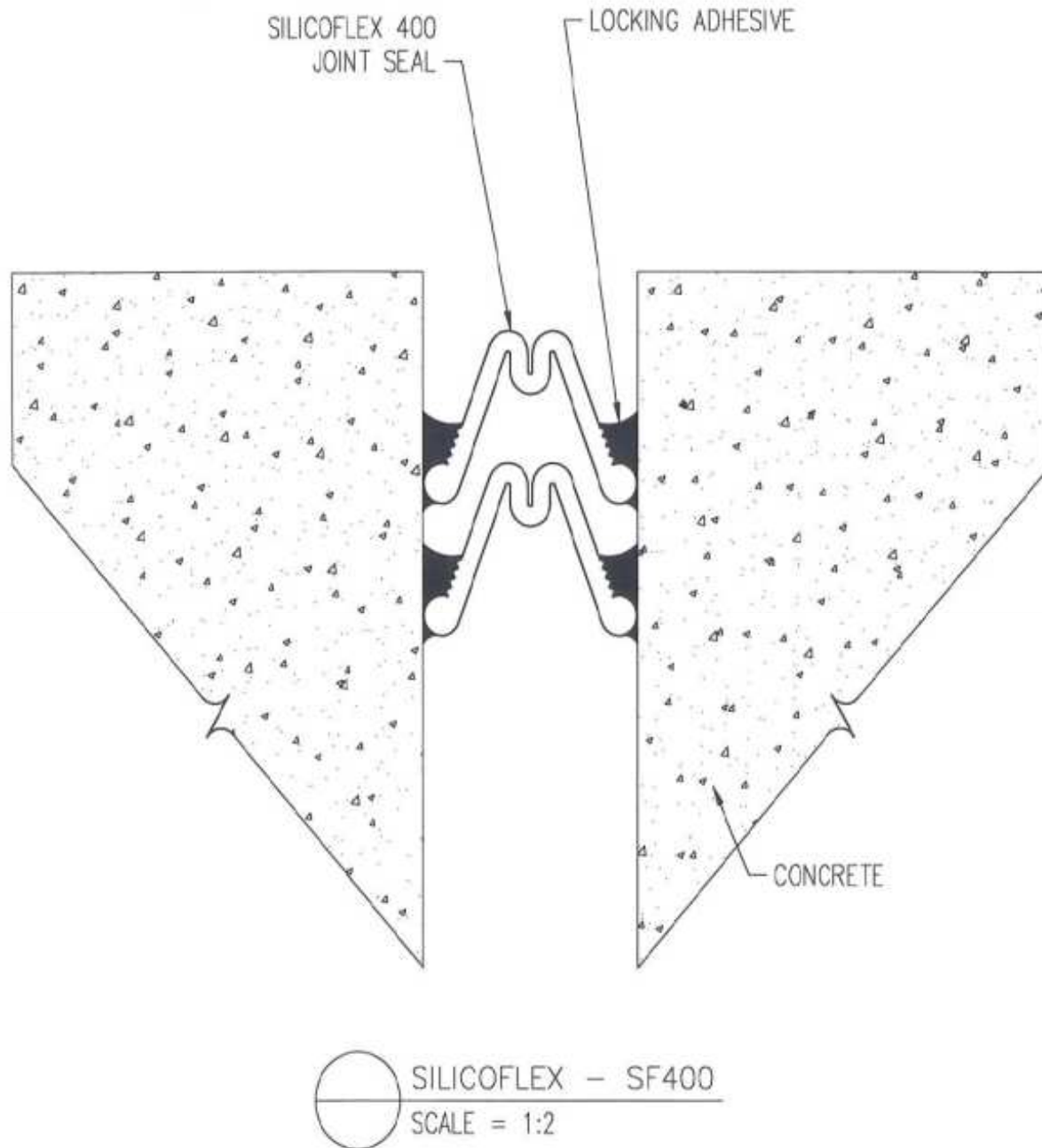

Silicoflex Testing



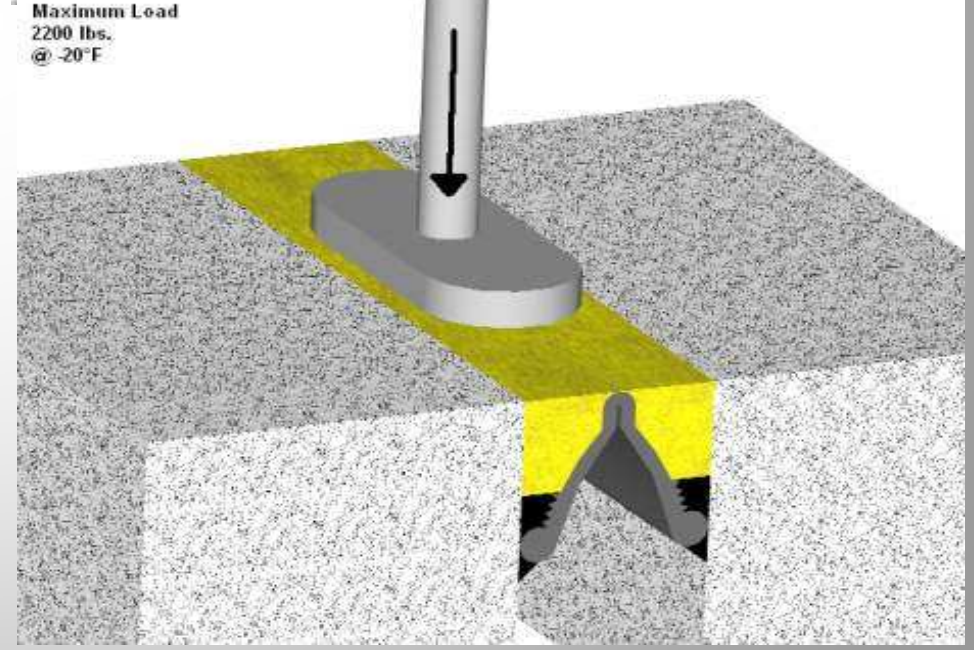
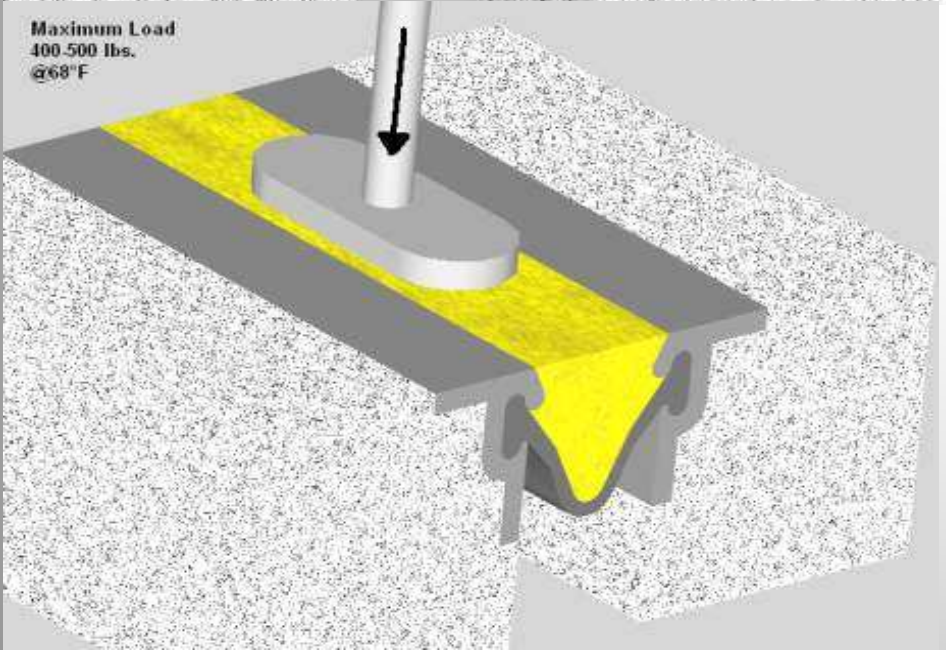
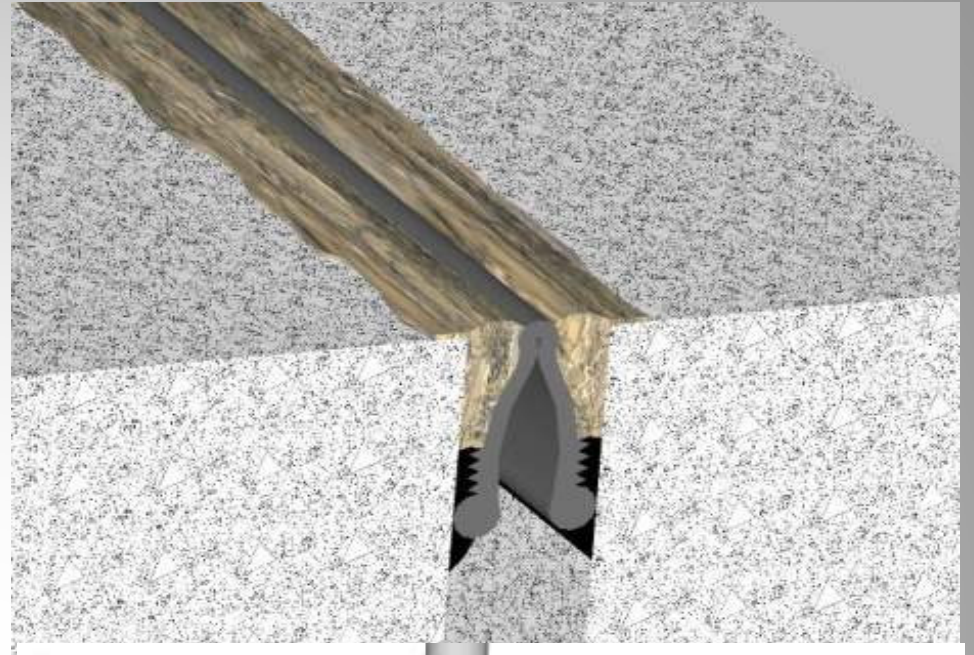
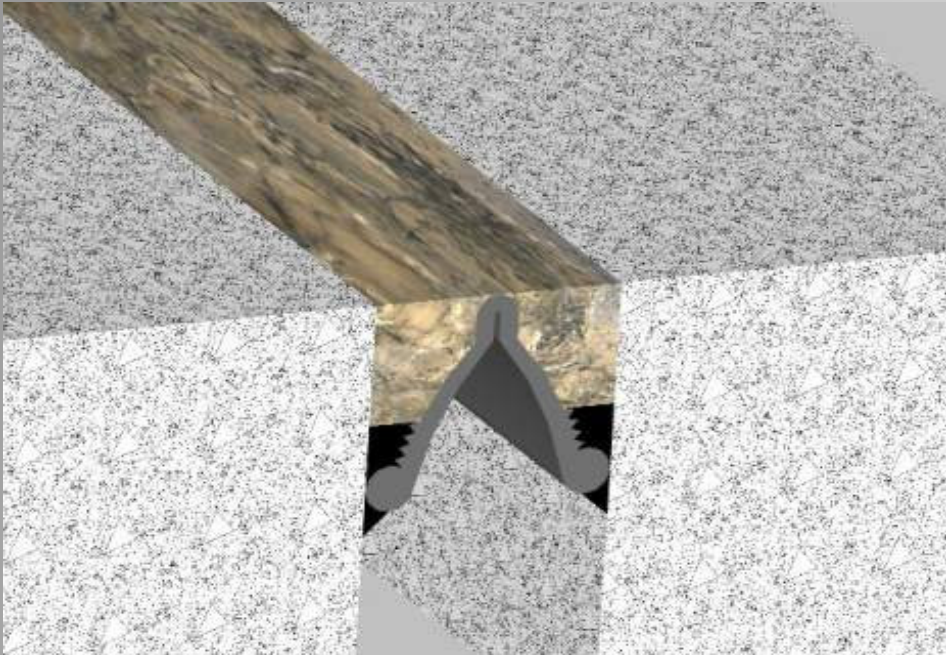



10/13/2010

AASHTO Midwest Bridge Preservation Conference – Detroit Michigan

Roe Enchayan, PE

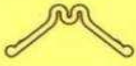

Sizing Chart

Model	Inst. Width	Max Closure	Max Opening
	1.0 - 2.0 in. (25-50 mm)	0.5 in. (13 mm)	2.0 in. (50 mm)
	1.25 - 3.0 in. (31-75 mm)	0.75 in. (19 mm)	3.0 in. (75 mm)
	2.5 - 4.0 in. (63-100 mm)	1.0 in. (25 mm)	5.0 in. (125 mm)



Silicoflex

- **Versatile Joint Seal**
- **Simple Installation**
- **Durable Material**
- **Rapid Installation**
- **Long Lasting Seal**
- **Maintenance Friendly**

Questions



10/13/2010

AASHTO Midwest Bridge Preservation Conference – Detroit Michigan

Roe Enchayan, PE